

General Description

The AAT3172 is a high output current, high efficiency, low noise, low profile charge pump DC/DC converter, ideal for multi-function LED photo-flash applications where solution cost, size, and efficiency are critical.

The dual charge pump in the AAT3172 is capable of delivering 600mA output current. Two current-controlled paths are available for users of dual flash LEDs that prefer current matching. Each LED channel can be easily programmed in 32 steps with a single GPIO output through the AS²Cwire™ (Advanced Simple Serial Control™) interface. This allows smooth transitions and flexible adjustment of brightness in flash or other lighting modes.

The tri-mode (1X/1.5X/2X) operation of the internal charge pump offers excellent power efficiency for both flash and movie modes. Combined with a low external parts count (two 1μF flying capacitors and one small bypass capacitor at V_{IN} and OUT), the AAT3172 is ideally suited for small, battery-powered applications.

The AAT3172 has a thermal management system to protect the device in the event of a short-circuit condition at the output pin. Built-in soft-start circuitry prevents excessive inrush current during start-up. The shutdown feature disconnects the load from V_{IN} and reduces quiescent current to less than 1.0μA.

The AAT3172 is available in the Pb-free, thermally-enhanced, 12-pin 3x3mm TDFN package.

Features

- V_{IN} Range: 2.7V to 5.5V
- 600mA Output Current
- Tri-Mode 1X/1.5X/2X in Current Mode
- Voltage Mode Operation: 1.5X, 100mA
- Dual Regulated Current Sinks
- Current Match Between Current Sinks
- 32 Current Steps Set by AS²Cwire
- 1μF Input, Output, and Flying Capacitors
- <1.0μA of Shutdown
- Small Application Circuit
- No Inductors
- Automatic Soft Start
- 12-Pin TDFN 3x3mm Package
- -40°C to +85°C Temperature Range

Applications

- Camera Phones
- Digital Still Cameras (DSCs)
- PDAs and Notebook PCs
- Smart Phones

Typical Application

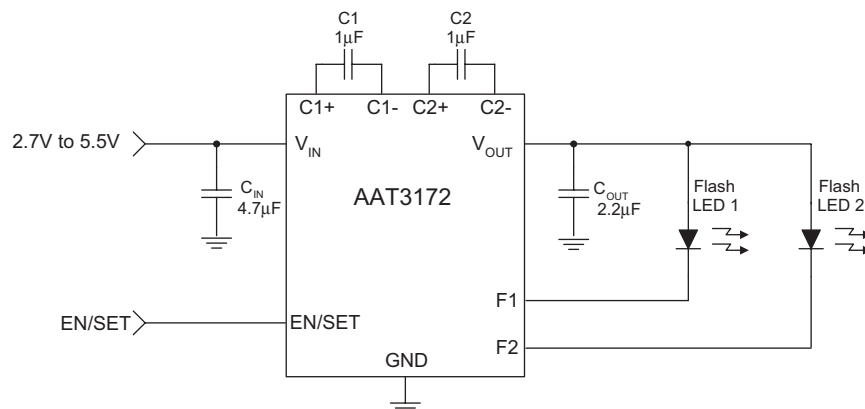

Pin Descriptions

Pin #	Symbol	Function
1, 12	VIN	Input power supply pin. Requires 4.7μF bypass capacitor to ground.
2	C1+	Flying capacitor C1 positive terminal. Connect a 1.0μF capacitor between C1+ and C1-.
3	C1-	Flying capacitor C1 negative terminal.
4	GND	Ground connection.
5	F1	Current sink input #1.
6	F2	Current sink input #2.
7	EN/SET	AS ² Cwire serial interface control pin.
8	N/C	No connection.
9	C2-	Flying capacitor C2 negative terminal.
10	C2+	Flying capacitor C2 positive terminal. Connect a 1μF capacitor between C2+ and C2-.
11	VOUT	Charge pump output. Requires 2.2μF capacitor connected between this pin and ground.
EP		Exposed paddle (bottom); connect to GND directly beneath package.

Pin Configuration

**TDFN33-12
(Top View)**

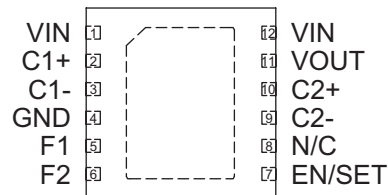

Absolute Maximum Ratings¹

T_A = 25°C, unless otherwise noted.

Symbol	Description	Value	Units
V _{IN}	Input Voltage	-0.3 to 6.0	V
V _{EN}	EN to GND Voltage	-0.3 to 6.0	V
V _{EN(MAX)}	Maximum EN to Input Voltage	V _{IN} + 0.3	V
I _{OUT}	Maximum DC Output Current	700	mA
T _J	Operating Junction Temperature Range	-40 to 150	°C
T _S	Storage Temperature Range	-65 to 150	°C
T _{LEAD}	Maximum Soldering Temperature (at leads, 10 sec)	300	°C

Thermal Information²

Symbol	Description	Value	Units
θ _{JA}	Maximum Thermal Resistance	50	°C/W
P _D	Maximum Power Dissipation	2.0	W

1. Stresses above those listed in Absolute Maximum Ratings may cause permanent damage to the device. Functional operation at conditions other than the operating conditions specified is not implied. Only one Absolute Maximum Rating should be applied at any one time.

2. Mounted on an FR4 board.



Electrical Characteristics1

$C_{IN} = 4.7\mu F$, $C_{OUT} = 2.2\mu F$, $C_1 = C_2 = 1.0\mu F$; $T_A = -40^\circ C$ to $+85^\circ C$, unless otherwise noted. Typical values are $T_A = 25^\circ C$, $V_{IN} = 3.6V$.

Symbol	Description	Conditions	Min	Typ	Max	Units
Power Supply						
V_{IN}	Input Voltage Range		2.7		5.5	V
$V_{OUT(MAX)}$	Maximum Output Voltage			5.5		V
I_{CC}	Operating Current	ON/OFF Standby Mode, Code Address = 4, Data = 2 1X, No Load Current		10 300		μA
		$3.0 \leq V_{IN} \leq 5.5$, 1.5X Mode, No Load Current		2.0	4.0	mA
		$3.0 \leq V_{IN} \leq 5.5$, 2X Mode, No Load Current		3.0	6.0	mA
$I_{SHDN(MAX)}$	V_{IN} Pin Shutdown Current	EN = 0			1.0	μA
$I_{OUT(MAX)}^2$	Maximum Output Current	$V_F = 3.6V$		600		mA
$I_{(D-Match)}$	Current Matching Between Outputs; High Current	$V_{IN} = 3.6V$, $T_A = 25^\circ C$, 428mA; Code Address = 3, Data = 2; Code Address = 0, Data = 4		8		%
$I_{(D-Match)}$	Current Matching Between Outputs; Low Current	$V_{IN} = 3.6V$, $T_A = 25^\circ C$, 100mA; Code Address = 3, Data = 1; Code Address = 0, Data = 1		8		%
I_{DX}	Output Current Accuracy	$T_A = 25^\circ C$, Code 1, HI Scale	270		330	mA
F_{CLK}	Clock Frequency			1		MHz
V_{REG}	Voltage Mode Regulation	EN/SET Code Address = 6, Data = 2	4.1	4.5	4.9	V
T_{SS}	Soft-Start Time			200		μs
EN/SET						
V_{IL}	Enable Threshold Low	$V_{IN} = 2.7V$			0.4	V
V_{IH}	Enable Threshold High	$V_{IN} = 5.5V$	1.4			V
$T_{EN/SET LO}$	EN/SET Low Time		0.3		60	μs
$T_{EN/SET HI MIN}$	Minimum EN/SET High Time			50		ns
$T_{EN/SET HI MAX}$	Maximum EN/SET High Time				60	μs
T_{OFF}	EN/SET Off Timeout				500	μs
T_{LAT}	EN/SET Latch Timeout				500	μs
Input Current	EN/SET Input Leakage		-1		1	μA

1. The AAT3172 is guaranteed to meet performance specifications from 0°C to 70°C. Specification over the -40°C to +85°C operating temperature range is assured by design, characterization, and correlation with statistical process controls.
 2. Mounted on an FR4 board.

Typical Characteristics

$V_{IN} = 3.6V$, $C_{IN} = 4.7\mu F$, $C_{OUT} = 2.2\mu F$, $C_1 = C_2 = 1\mu F$, $T_A = 25^\circ C$, unless otherwise noted.

Efficiency vs. Supply Voltage

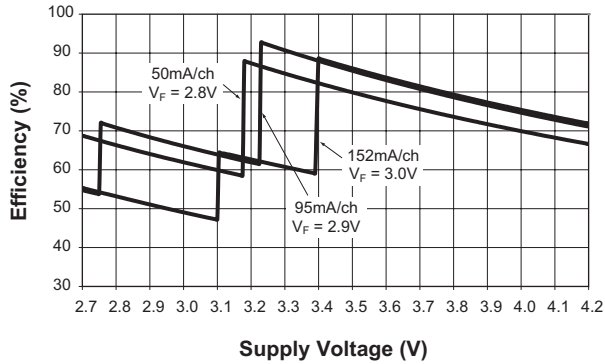

Turn-On to 1X Mode
($V_{IN} = 4.2V$; 50mA/ch Load)

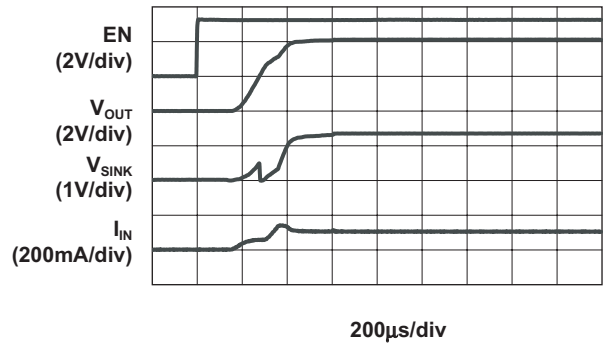

Turn-On to 1.5X Mode
($V_{IN} = 3.2V$; 50mA/ch Load)

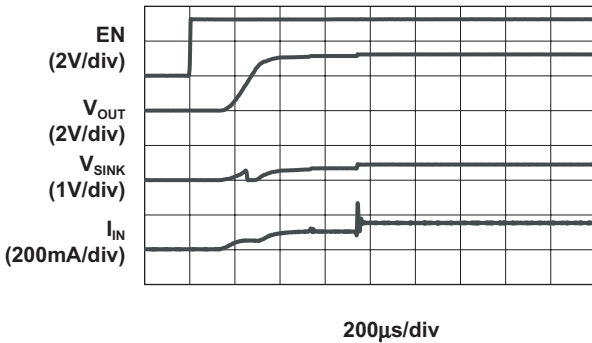

Turn-On to 1X Mode
($V_{IN} = 4.2V$; 300mA/ch Load)

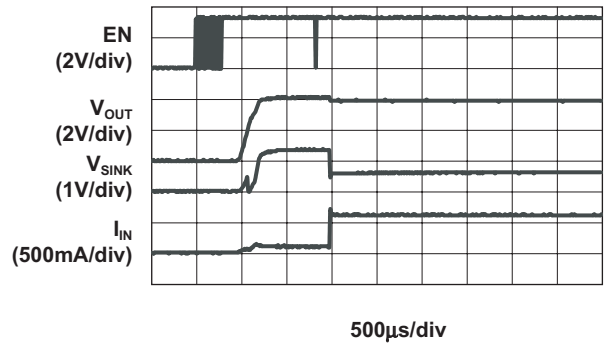

Turn-On to 2X Mode
($V_{IN} = 3.2V$; 300mA/ch Load)

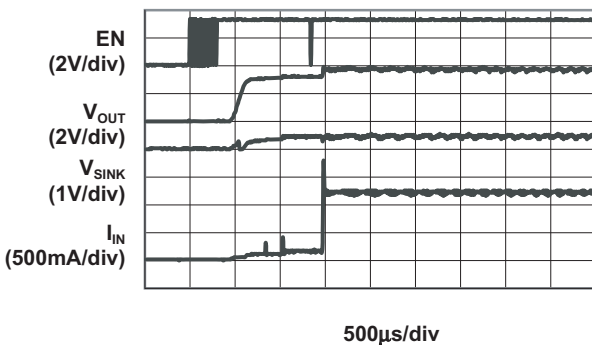

Turn-Off from 1.5X Mode
($V_{IN} = 3.2V$; 50mA/ch Load)

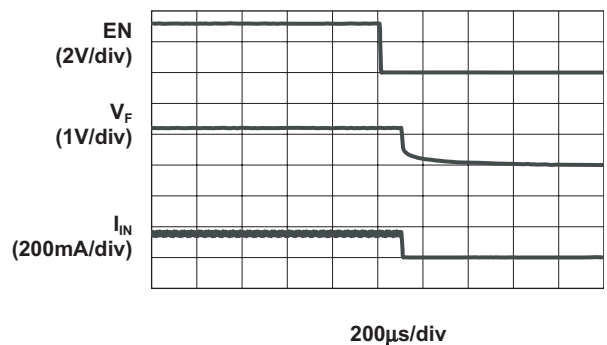

Typical Characteristics

$V_{IN} = 3.6V$, $C_{IN} = 4.7\mu F$, $C_{OUT} = 2.2\mu F$, $C_1 = C_2 = 1\mu F$, $T_A = 25^\circ C$, unless otherwise noted.

Load Characteristic
($V_{IN} = 3.0V$; 1.5X Mode; 50mA/ch Load)

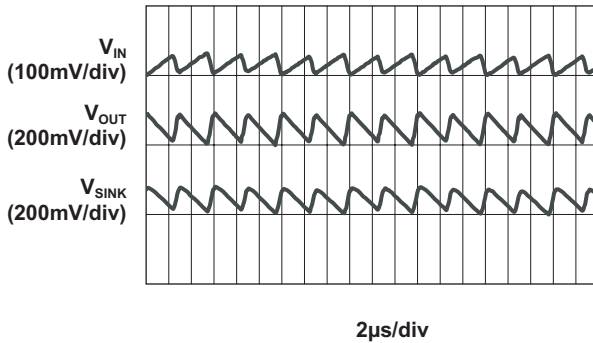

Load Characteristic
($V_{IN} = 3.6V$; 1.5X Mode; 152mA/ch Load)

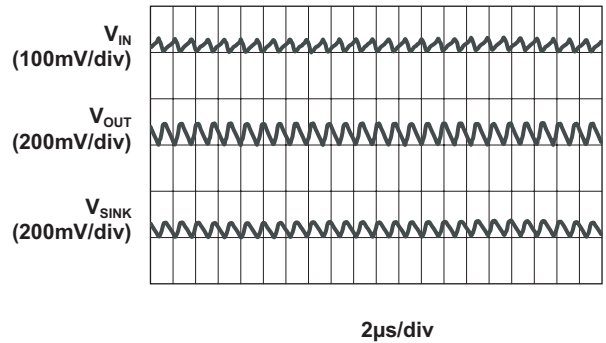

Load Characteristic
($V_{IN} = 2.8V$; 2X Mode; 152mA/ch Load)

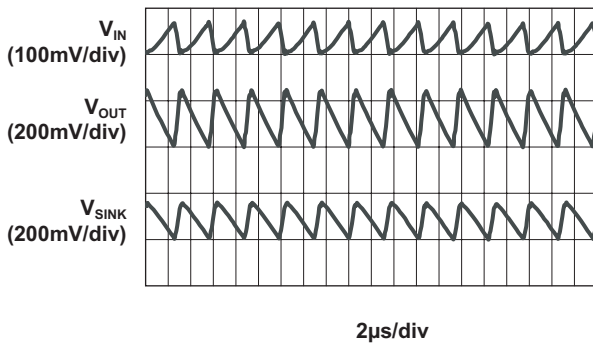

Voltage Mode Load Regulation

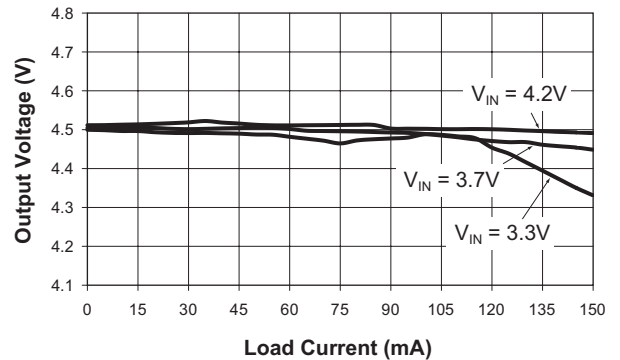

Voltage Mode Line Regulation

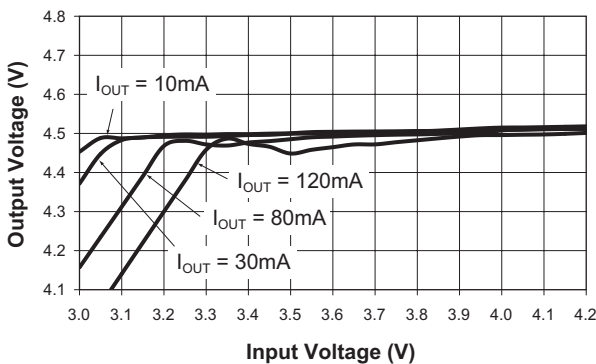

Voltage Mode Load Response
($V_{IN} = 3.7V$)

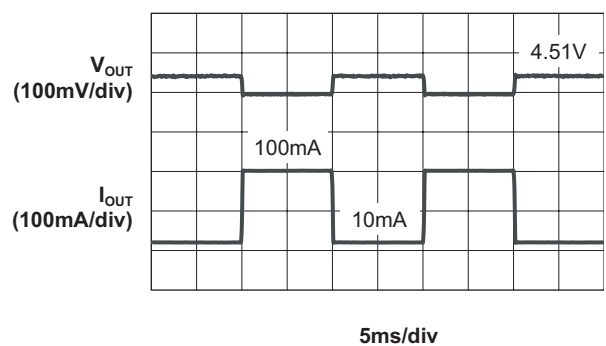

Typical Characteristics

$V_{IN} = 3.6V$, $C_{IN} = 4.7\mu F$, $C_{OUT} = 2.2\mu F$, $C_1 = C_2 = 1\mu F$, $T_A = 25^\circ C$, unless otherwise noted.

Voltage Mode Load Response
($V_{IN} = 3.3V$)

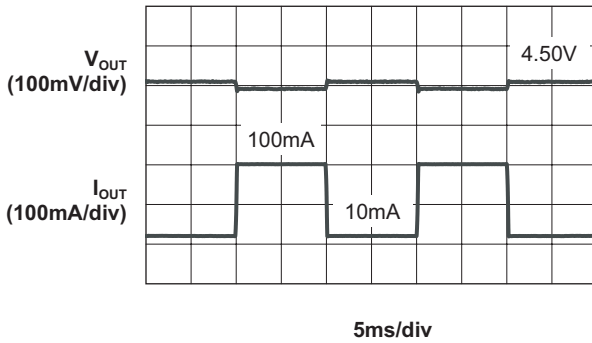

Voltage Mode Line Response
(100mA Load)

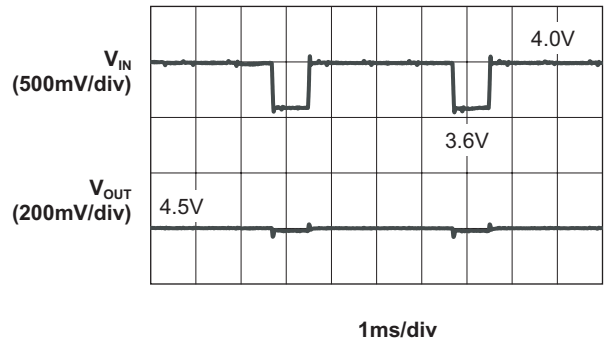

T_{LAT} vs. V_{IN}

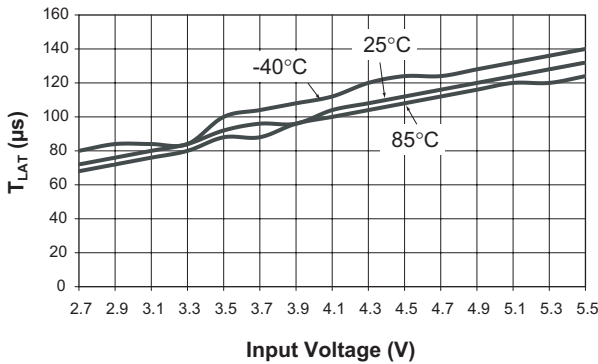

T_{OFF} vs. V_{IN}

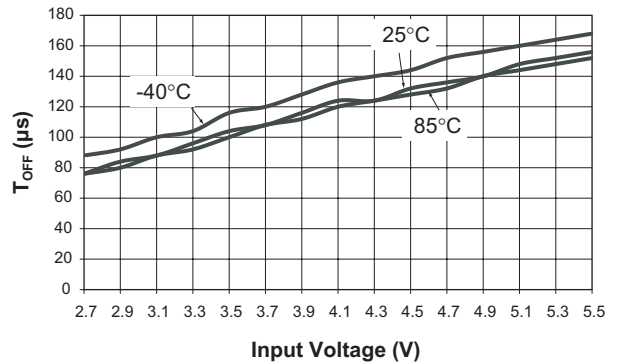

V_{IH} vs. V_{IN} Over-Temperature

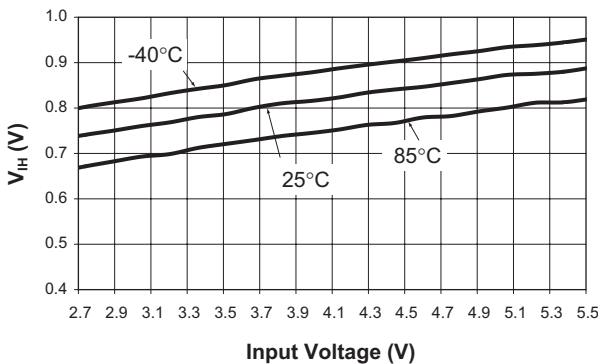

V_{IL} vs. V_{IN} Over-Temperature

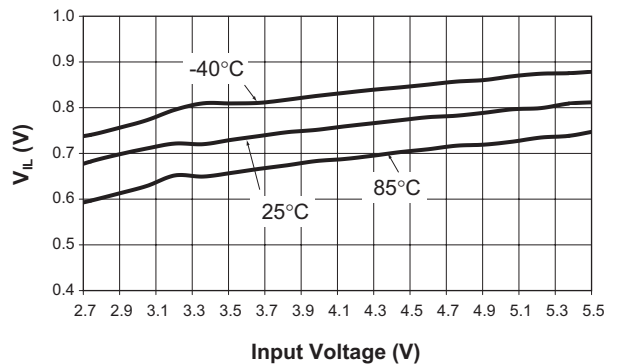

Functional Block Diagram

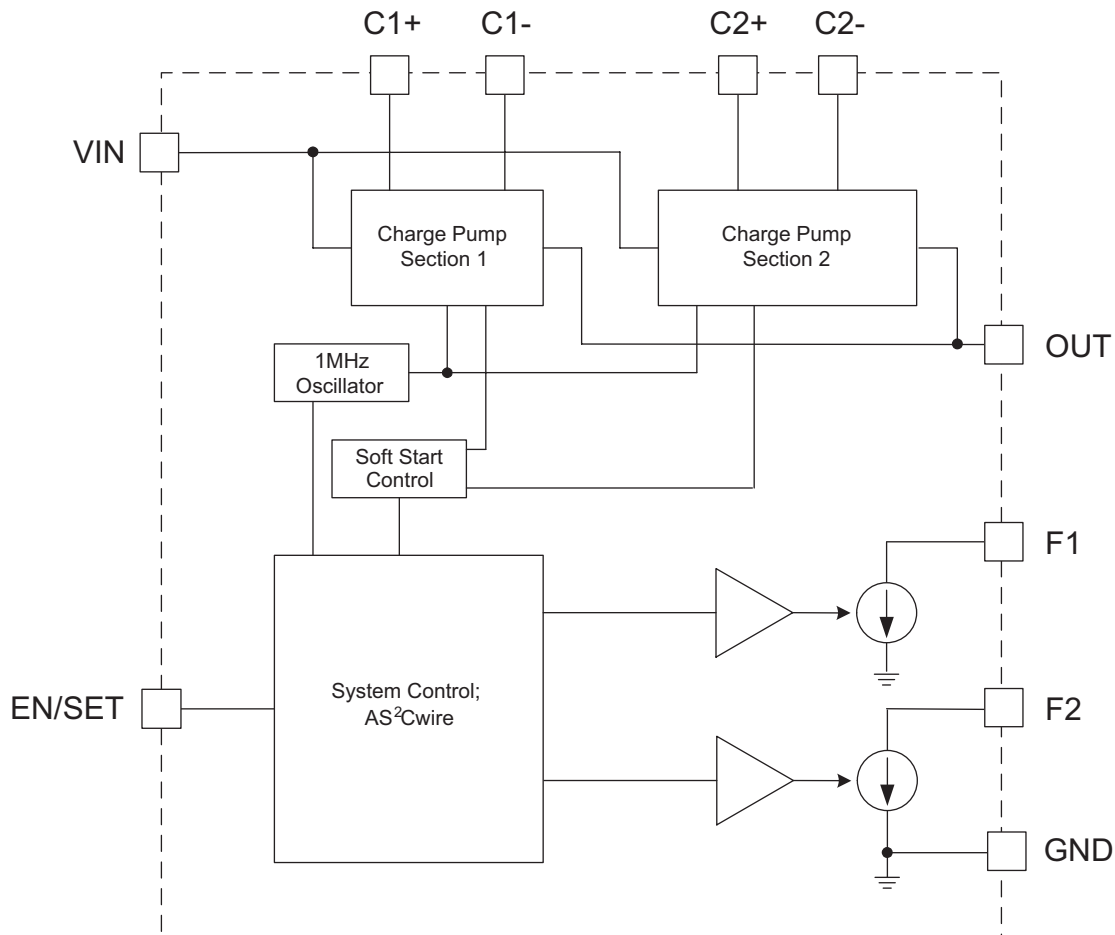

Functional Description

The AAT3172 is a high efficiency, low noise, dual stage tri-mode 1X/1.5X/2X charge pump device intended for photo-flash LED applications. The AAT3172 requires only four external components: two 1.0 μ F ceramic capacitors for the charge pump flying capacitors, one 4.7 μ F ceramic capacitor for C_{IN} , and one 2.2 μ F ceramic capacitor for C_{OUT} .

The charge pump is designed to deliver load currents up to 600mA. The dual stage charge pump section contains soft-start circuitry to prevent excessive in-rush current during start-up. System efficiency is maximized with a tri-mode, dual stage charge pump topology. The internal clock oscillator, which operates at 1MHz, allows the use of small external components.

The tri-mode charge pump architecture optimizes power conversion efficiency. Depending upon the combination of load current, input voltage, and nominal LED forward voltage, the charge pump will operate in a 1X, 1.5X, or 2X mode to generate the output voltage required to power the load for a programmed constant current setting. This results in significant power savings over voltage doubling architectures, especially when the LEDs are continuously operated at lower current levels in movie viewing or flashlight modes.

Constant Current Channels

The AAT3172 contains two programmable constant current sinks for integrated flash circuit control. Efficiency is optimized with the low dropout characteristic of the current sinks. The low dropout performance extends the

battery operating range for 1X and 1.5X modes, improving efficiency and extending battery life. Each constant current sink is programmable through the AS²Cwire serial interface. Independent current settings can be used for a multistage flash LED control. This feature allows users to conveniently drive separate dual flash LEDs directly while achieving good brightness matching. Also, F1 and F2 can be connected together for single output configuration.

Modes of Operation

In addition to the data registers that set the current levels for the two current sinks, the AAT3172 has three mode registers. Register 3 is the HI/LO mode register. It sets the maximum per channel current level to either 300mA or 50mA. Each channel can be set independently so one channel can be for flash while the other can be in a low constant current mode.

Register 4 is the ON/OFF register. When set with Data = 1, both current sources are enabled (default); when set with Data = 2, both current sources are disabled. When Register 4 is set to OFF, the device is in standby mode with significantly reduced quiescent current.

The AAT3172 also includes a regulated output voltage mode setting. By setting Register 6 with Data = 2 for voltage mode, the charge pump delivers a regulated 4.5V output that continuously operates in 1.5X mode. It is suitable for driving loads of up to 100mA. The voltage mode may be used to drive LEDs with ballast resistors. Driving either F1 or F2 in current mode will override the voltage mode state until F1 and F2 are set back to zero current by either data or mode register. Setting Register 5 with Data = 1 will reset the mode back to current mode and the charge pump output voltage will regulate appropriately.

AS²Cwire Serial Interface

The AAT3172 utilizes the AS²Cwire serial interface to enable/disable the charge pump, set the operating mode, and adjust the output current level of each constant current sink. Each current sink can be independently programmed with sixteen current levels (see table below). AS²Cwire incorporates addressing to program the operating modes and current level settings.

Constant Current Sink Nominal Programming Levels

Data	300mA HI Scale I_{SINK} (mA/ch)	50mA LO Scale I_{SINK} (mA/ch)
1	300	50
2	267	44
3	238	40
4	214	36
5	190	32
6	167	28
7	152	25
8	133	22
9	119	20
10	105	17
11	95	16
12	86	14
13	76	13
14	67	11
15	62	10
16	0	0

AS²Cwire relies on the number of rising edges of the EN/SET pin to address and load the registers. AS²Cwire latches data or address after the EN/SET pin has been held high for time T_{LAT} . Address or data is differentiated by the number of EN/SET rising edges. Since the data registers are 4 bits each, the differentiating number of pulses is 24 or 16, so that Address 0 is signified by 17 rising edges, Address 1 by 18 rising edges, and so forth. Data is set to any number of rising edges between 1 and including 16. A typical write protocol is a burst of EN/SET rising edges, signifying a particular address, followed by a pause with EN/SET held high for the T_{LAT} timeout period, a burst of rising edges signifying data, and a T_{LAT} timeout for the data registers. Once an address is set, then multiple writes to that address are allowed where only data is issued.

When EN/SET is held low for an amount of time greater than T_{OFF} , the AAT3172 enters into shutdown mode and draws less than 1 μ A from the supply. Address 0 is the default address on the first rising edge after the AAT3172 has been disabled. After shutdown, if only data is issued with the first rising edge (i.e., 1 - 16 edges, no address given), both current sinks will be programmed since the default will be Address 0.

AS²Cwire Serial Interface Addressing

Address	EN/SET Rising Edges	Data Register
0	17	F1 and F2 Current Scale
1	18	F1 Current Scale
2	19	F2 Current Scale
3	20	HI/LO
4	21	ON/OFF
5	22	Reserved
6	23	Voltage/Current Mode

HI/LO Scale Register (Address 3)

Data	F1	F2
1	LO	LO
2	HI	HI
3	LO	HI
4	HI	LO

ON/OFF Register (Address 4)

Data	MODE
1	ON
2	OFF

Voltage Register (Address 6)

Data	MODE
1	Current
2	Voltage

Thermal Protection

The AAT3172 has a thermal protection circuit that will shut down the charge pump if the die temperature rises above the thermal limit, as is the case during a short circuit of the OUT pin.

AS²Cwire Serial Interface Timing

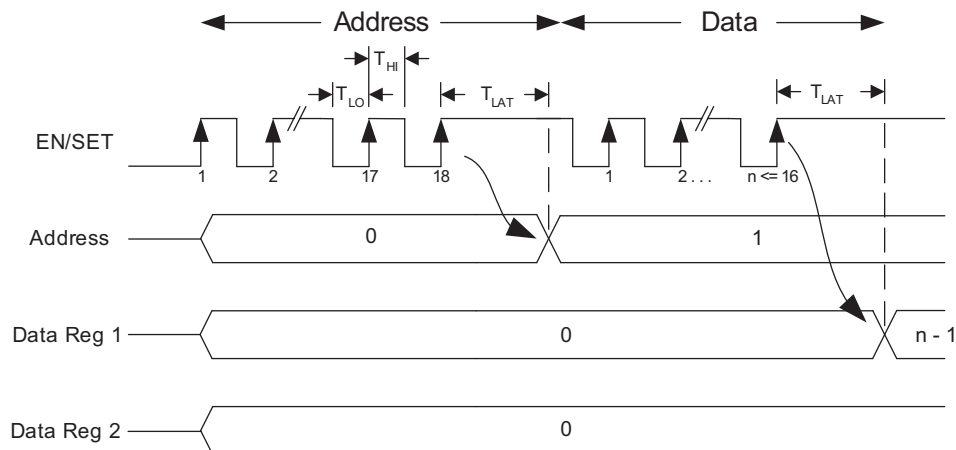

Applications Information

AS²Cwire Programming

Generally, programming the AAT3172 is achieved by submitting bursts of address and data edges to the EN/SET pin. However, in some cases multiple bursts of address and data are needed to enable a particular operating mode. In other cases, only a single burst of data edges is required.

To enable both flash channels to a current setting on the LO scale, the user submits a single burst of address and data edges. To enable both flash channels to a current setting on the HI scale, the user must submit a burst of address and data edges to program the current setting level, and then submit a second burst of address and data edges to program the HI/LO scale register to the HI scale.

Shortcuts can also be used. If the device is in shutdown, both flash channels can be enabled to a setting on the LO scale by just giving a single burst of data edges. The address edges are not needed because all registers are reset during shutdown and address 0 is the default.

Further, a single burst of data edges can be used to change from one setting to another for the last address. The address register is not reset after each write; therefore, submitting address edges is only required when changing the address.

Additional Applications

The constant voltage mode feature of the AAT3172 allows the user to combine the flash feature with additional applications. Additional applications such as auxiliary lighting and status LEDs can be added while eliminating the need for an additional power supply, which is normally required. Since the constant voltage mode can supply a regulated output at up to 100mA load, it is capable of driving five LEDs at 20mA each. It is suitable for keypad lighting, status lighting, and other applications where a 4.5V power supply could be used.

When enabling constant voltage mode, the LED channels F1 and F2 are automatically disabled so current does not flow through the flash LED during constant voltage mode. Because of this, very little programming is required. The user just addresses the voltage mode register and programs it to voltage mode.

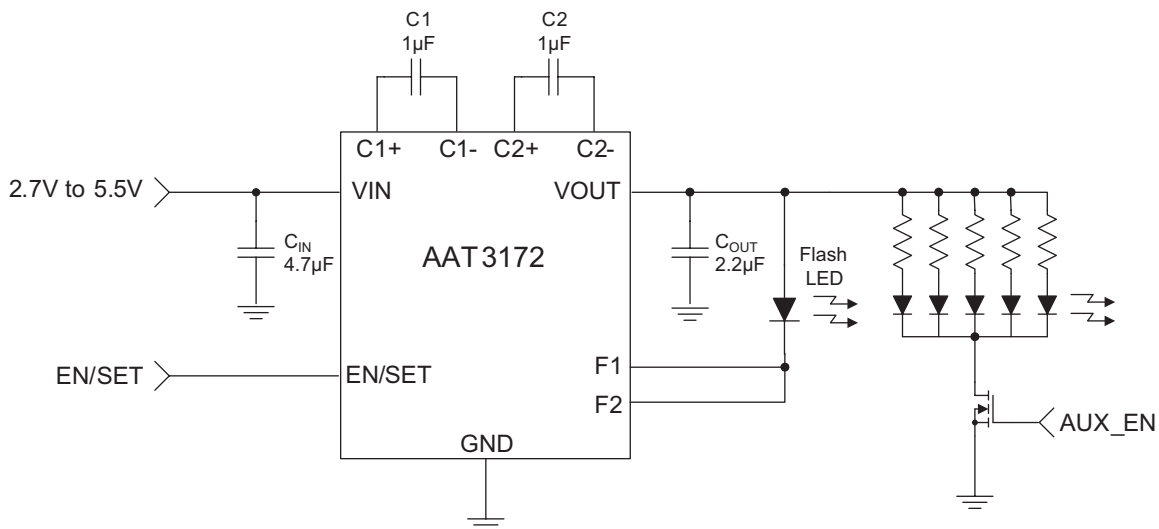

Figure 1: Flash Plus Auxiliary Lighting.

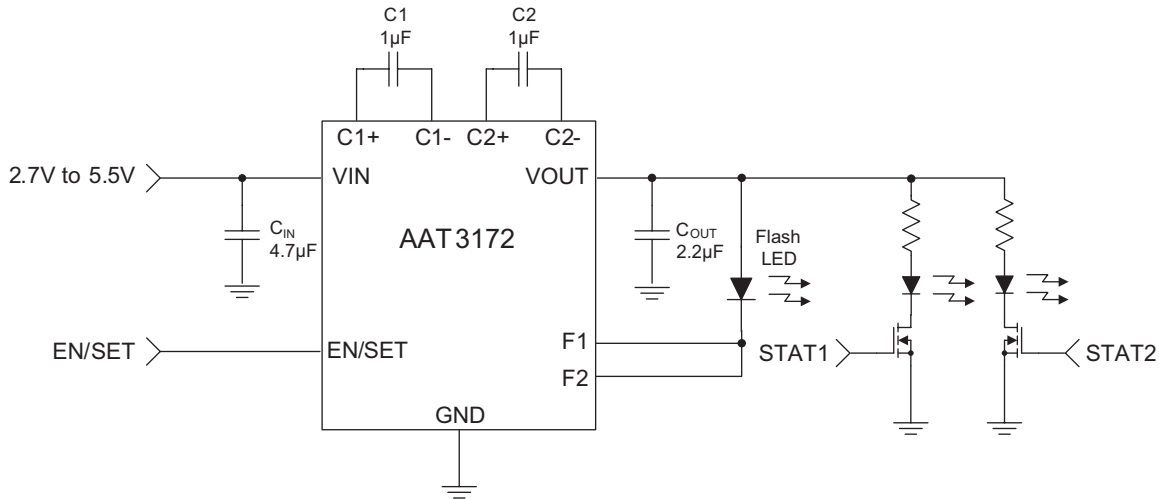

Figure 2: Flash Plus Status Lighting.

LED Selection

The AAT3172 is designed to drive high-intensity white LEDs. It is particularly suitable for LEDs with an operating forward-voltage in the range of 4.2V to 1.5V.

The charge pump device can also drive other loads that have similar characteristics to white LEDs. For various load types, the AAT3172 provides a high-current, programmable ideal constant current source.

Device Power Efficiency

The AAT3172 power conversion efficiency depends on the charge pump mode. By definition, device efficiency is expressed as the output power delivered to the LED divided by the total input power consumed.

$$\eta = \frac{P_{OUT}}{P_{IN}}$$

When the input voltage is sufficiently greater than the LED forward voltage, the device optimizes efficiency by operating in 1X mode. In 1X mode, the device is working as a bypass switch and passing the input supply directly to the output. The power conversion efficiency can be approximated by:

$$\eta = \frac{V_F \cdot I_{LED}}{V_{IN} \cdot I_{IN}} \approx \frac{V_F}{V_{IN}}$$

Due to the very low 1X mode quiescent current, the input current nearly equals the current delivered to the

LED. Further, the low-impedance bypass switch introduces negligible voltage drop from input to output.

The AAT3172 further maintains optimized performance and efficiency by detecting when the input voltage is not sufficient to sustain LED current. The device automatically switches to 1.5X mode when the input voltage drops too low in relation to the LED forward voltage.

In 1.5X mode, the output voltage can be boosted to 3/2 the input voltage. The 3/2 conversion ratio introduces a corresponding 1/2 increase in input current. For ideal conversion, the 1.5X mode efficiency is given by:

$$\eta = \frac{V_F \cdot I_{LED}}{V_{IN} \cdot 1.5I_{IN}} = \frac{V_F}{1.5 \cdot V_{IN}}$$

Similarly, when the input falls further, such that 1.5X mode can no longer sustain LED current, the device will automatically switch to 2X mode. In 2X mode, the output voltage can be boosted to twice the input voltage. The doubling conversion ratio introduces a corresponding doubling of the input current. For ideal conversion, the 2X mode efficiency is given by:

$$\eta = \frac{V_F \cdot I_{LED}}{V_{IN} \cdot 2I_{IN}} = \frac{V_F}{2 \cdot V_{IN}}$$

Capacitor Selection

Careful selection of the four external capacitors (C_{IN} , C_1 , C_2 , and C_{OUT}) is important because they will affect turn-on

time, output ripple, and transient performance. Optimum performance will be obtained when low equivalent series resistance (ESR) ($<100\text{m}\Omega$) ceramic capacitors are used. A value of $1\mu\text{F}$ for the flying capacitors is a good starting point when choosing capacitors. If the LED current sinks are only programmed for light current levels, then the capacitor size may be decreased.

Ceramic composition capacitors are highly recommended over all other types of capacitors for use with the AAT3172. Ceramic capacitors offer many advantages over their tantalum and aluminum electrolytic counterparts. A ceramic capacitor typically has very low ESR, is lowest cost, has a smaller PCB footprint, and is non-polarized. Low ESR ceramic capacitors help maximize charge pump transient response.

Equivalent Series Resistance

ESR is an important characteristic to consider when selecting a capacitor. ESR is a resistance internal to a capacitor that is caused by the leads, internal connections, size or area, material composition, and ambient temperature. Capacitor ESR is typically measured in milliohms for ceramic capacitors and can range to more than several ohms for tantalum or aluminum electrolytic capacitors.

Ceramic Capacitor Materials

Ceramic capacitors less than $0.1\mu\text{F}$ are typically made from NPO or COG materials. NPO and COG materials typically have tight tolerance and are stable over temperature. Large capacitor values are typically composed of X7R, X5R, Z5U, or Y5V dielectric materials. Large ceramic capacitors are often available in lower-cost dielectrics, but capacitors greater than $4.7\mu\text{F}$ are not typically required for AAT3172 applications.

Capacitor area is another contributor to ESR. Capacitors that are physically large will have a lower ESR when compared to an equivalent material, smaller capacitor. These larger devices can improve circuit transient response when compared to an equal value capacitor in a smaller package size.

PCB Layout

To achieve adequate electrical and thermal performance, careful attention must be given to the PCB layout. In the worst-case operating condition, the chip must dissipate considerable power at full load. Adequate heat-sinking must be achieved to ensure intended operation.

Figure 3 illustrates an example of an adequate PCB layout. The bottom of the package features an exposed metal paddle. The exposed paddle acts, thermally, to transfer heat from the chip and, electrically, as a ground connection.

The junction-to-ambient thermal resistance (θ_{JA}) for the package can be significantly reduced by following a couple of important PCB design guidelines.

The PCB area directly underneath the package should be plated so that the exposed paddle can be mated to the top layer PCB copper during the re-flow process. This area should also be connected to the top layer ground pour when available. Further, multiple copper plated thru-holes should be used to electrically and thermally connect the top surface paddle area to additional ground plane(s) and/or the bottom layer ground pour.

The chip ground is internally connected to both the paddle and the GND pin. The GND pin conducts large currents and it is important to minimize any differences in potential that can result between the GND pin and exposed paddle. It is good practice to connect the GND pin to the exposed paddle area using a trace as shown in Figure 3.

The flying capacitors C1 and C2 should be connected close to the chip. Trace length should be kept short to minimize path resistance and potential coupling. The input and output capacitors should also be placed as close to the chip as possible.

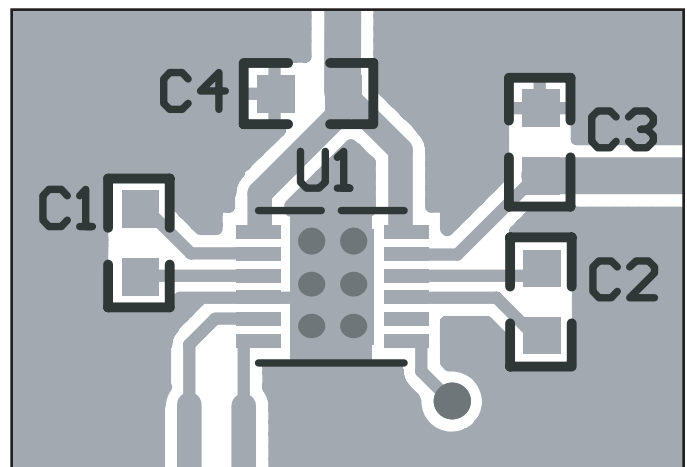

Figure 3: Example PCB Layout.

Ordering Information

Package	Marking ¹	Part Number (Tape and Reel) ²
TDFN33-12	QLXYY	AAT3172IWP-T1



All AnalogicTech products are offered in Pb-free packaging. The term “Pb-free” means semiconductor products that are in compliance with current RoHS standards, including the requirement that lead not exceed 0.1% by weight in homogeneous materials. For more information, please visit our website at <http://www.analogictech.com/about/quality.aspx>.

Package Information³

TDFN33-12

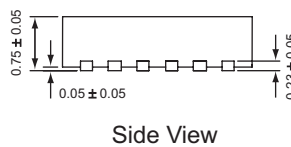
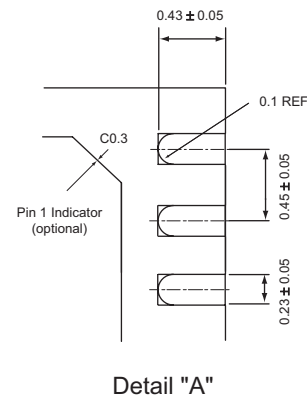
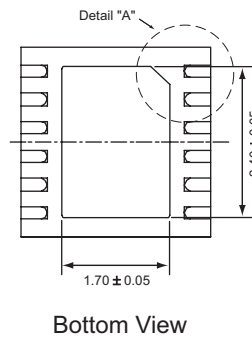
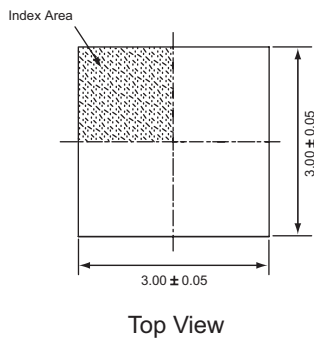

All dimensions in millimeters.

1. XYY = assembly and date code.
 2. Sample stock is generally held on part numbers listed in **BOLD**.
 3. The leadless package family, which includes QFN, TQFN, DFN, TDFN and STDN, has exposed copper (unplated) at the end of the lead terminals due to the manufacturing process. A solder fillet at the exposed copper edge cannot be guaranteed and is not required to ensure a proper bottom solder connection.

**ChargePump™****High Current LED Flash Driver Charge Pump IC**

Advanced Analogic Technologies, Inc.
3230 Scott Boulevard, Santa Clara, CA 95054
Phone (408) 737-4600
Fax (408) 737-4611



© Advanced Analogic Technologies, Inc.
AnalogicTech cannot assume responsibility for use of any circuitry other than circuitry entirely embodied in an AnalogicTech product. No circuit patent licenses, copyrights, mask work rights, or other intellectual property rights are implied. AnalogicTech reserves the right to make changes to their products or specifications or to discontinue any product or service without notice. Except as provided in AnalogicTech's terms and conditions of sale, AnalogicTech assumes no liability whatsoever, and AnalogicTech disclaims any express or implied warranty relating to the sale and/or use of AnalogicTech products including liability or warranties relating to fitness for a particular purpose, merchantability, or infringement of any patent, copyright or other intellectual property right. In order to minimize risks associated with the customer's applications, adequate design and operating safeguards must be provided by the customer to minimize inherent or procedural hazards. Testing and other quality control techniques are utilized to the extent AnalogicTech deems necessary to support this warranty. Specific testing of all parameters of each device is not necessarily performed. AnalogicTech and the AnalogicTech logo are trademarks of Advanced Analogic Technologies Incorporated. All other brand and product names appearing in this document are registered trademarks or trademarks of their respective holders.